

ELECTRONICS

(FINAL)

1. The coordination number of Cu is
 - (A) 1
 - (B) 8
 - (C) 12
 - (D) 6

2. In a PN-junction diode not connected to any circuit
 - (A) the potential is the same everywhere.
 - (B) there is an electric field at the junction directed from the N-type side to the p-type side.
 - (C) the p-type is a higher potential than the N-type side.
 - (D) there is an electric field at the junction directed from the p-type side to the N-type side.

3. Consider the following statements:
Piezo-electric materials serve as
 1. A source of ultrasonic waves
 2. When electric field is applied, the mechanical dimensions of the substances are not at all altered.
 3. Converts electrical energy to mechanical and vice versa.
 4. Converts thermal energy to electrical energyWhich of the above statements is/are correct?
 - (A) 1 only
 - (B) 2 and 3 only
 - (C) 1 and 3 only
 - (D) 1, 2, 3 and 4

4. A UJT exhibits negative resistance region
 - (a) Before the peak point
 - (b) Between peak and valley points
 - (c) After the valley point
 - (d) Both (a) and (c)
 - (A) (b) only
 - (B) (a), (c)
 - (C) (c) only
 - (D) (b), (d)

5. When transistors are used in digital circuits they usually operate in the
 - (A) active region
 - (B) breakdown region
 - (C) saturation and cut off regions
 - (D) linear region

6. Once a PAL has been programmed
- (A) it cannot be reprogrammed
 - (B) its outputs are only active HIGHS
 - (C) its outputs are only active LOWs
 - (D) its logic capacity is lost
7. Due to which configuration feature latches constructed with NOR and NAND gates tend to remain in the latched condition?
- (A) Asynchronous operation
 - (B) Low input voltages
 - (C) Gate impedance
 - (D) Cross coupling
8. The equation for the output frequency of a 555 timer operating in the astable mode is: $f = \frac{1.43}{(R_1 + 2R_2) \times C_1}$
- What value of C_1 will be required if $R_1 = 1\text{ k}\Omega$, $R_2 = 1\text{ k}\Omega$, and $f = 1\text{ kHz}$?
- (A) $0.33\ \mu F$
 - (B) $0.48\ \mu F$
 - (C) $480\ \mu F$
 - (D) 33 nF
9. A 4-bit R/2R digital-to-analog (DAC) converter has a reference of 5 volts. What is the analog output for the input code 0101.
- (A) 0.3125 V
 - (B) 3.125 V
 - (C) 0.78125 V
 - (D) -3.125 V
10. What is the resolution of a digital-to-analog converter (DAC)?
- (A) It is the comparison between the actual output of the converter and its expected output.
 - (B) It is the deviation between the ideal straight-line output and the actual output of the converter.
 - (C) It is the smallest analog output change that can occur as a result of an increment in the digital input.
 - (D) It is its ability to resolve between forward and reverse steps when sequenced over its entire range.
11. The software used to drive microprocessor-based systems is called
- (A) assembly language programe
 - (B) firmware
 - (C) BASIC interpreter instructions
 - (D) flowchart instructions

12. How many storage locations are available when a memory device has twelve address lines?
- (A) 144 (B) 512
(C) 2048 (D) 4096
13. Which of the following RAM timing parameters determine(s) its operating speed?
- (A) t_{acc} (B) T_{aa} and t_{acs}
(C) t_1 and t_3 (D) t_{rc} and t_{wc}
14. If a diode is connected in anti parallel with a SCR, then
- (A) both turn off power loss and turn off time decrease.
(B) turn off power loss decreases, but turn off time increases.
(C) turn off power loss increases, but turn off time decreases.
(D) the arrangement works as a triac.
15. In a LVDT, the secondary voltages
- (A) are independent of the core position.
(B) vary unequally depending on the core position.
(C) vary equally depending on the core position.
(D) are always in phase quadrature.
16. The formula $I_C = \left(\frac{V_C}{\tau}\right)C$ shows that for a given capacitor, if the voltage changes at a constant rate with respect to time, the current will
- (A) increase (B) decrease
(C) be constant (D) decrease logarithmically
17. The observation that a bubbled input OR gate is interchangeable with a bubbled output AND gate is referred to as
- (A) a Karnaugh map
(B) DeMorgan's second theorem
(C) the commutative law of addition
(D) the associative law of multiplication
18. Derived units are obtained from various combinations of
- (A) electrical quantities (B) fundamental units
(C) metric prefixes (D) international standards

19. Permeability is the inverse equivalent of which electrical term?

- (A) Voltage (B) Current
(C) Resistance (D) Conductance

20. Which electromagnetic device uses brushes and a commutator?

- (A) A speaker (B) A dc generator
(C) A relay (D) A solenoid

21. What is the power dissipated by R_2 , R_4 and R_6 ?

(P_2 , P_4 and P_6 are power dissipated in R_2 , R_4 and R_6 respectively)

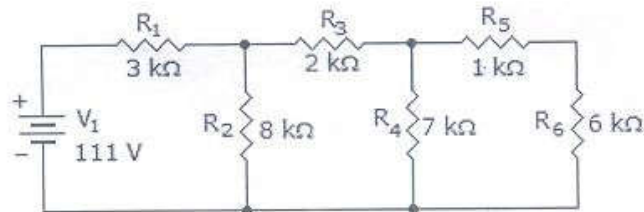

- (A) $P_2=417$ mW, $P_4 = 193$ mW, $P_6 = 166$ mW
(B) $P_2=407$ mW, $P_4 = 183$ mW, $P_6 = 156$ mW
(C) $P_2=397$ mW, $P_4 = 173$ mW, $P_6 = 146$ mW
(D) $P_2=387$ mW, $P_4 = 163$ mW, $P_6 = 136$ mW

22. In a series-parallel circuit, individual component power dissipations are calculated using

- (A) individual component parameters.
(B) a percent of the voltage division ratio squared.
(C) total current squared multiplied by the resistor values.
(D) a percent of the total power depending on resistor ratios.

23. Calculate the value of V_{DS} .

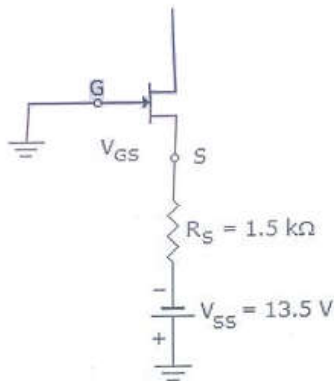

- (A) 0 V (B) 0.35 V
(C) 3.8 V (D) 33.5 V

24. Given the values of V_{DQ} and I_{DQ} for this circuit, determine the required values of R_D and R_S .

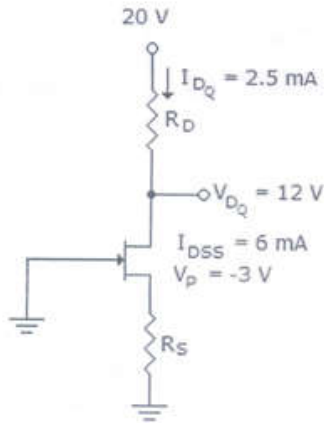

- (A) $2k\Omega, 2k\Omega$ (B) $1k\Omega, 5.3k\Omega$
 (C) $3.2k\Omega, 400\Omega$ (D) $2.5k\Omega, 5.3k\Omega$
25. Common-emitter amplifier has voltage gain, current gain, power gain and input impedance.
- (A) high, low, high, low (B) high, high, high, low
 (C) low, low, low, high (D) low, low, high, high
26. The advantage of a Sziklai pair over a Darlington pair is
- (A) higher current gain
 (B) less input voltage is needed to turn it on
 (C) higher input impedance
 (D) higher voltage gain
27. The absorption of radio waves by atmosphere depends on
- (A) their frequency
 (B) their distance from the transmitter
 (C) the polarization of atmosphere
 (D) the polarization of the waves
28. The phase shift through the input of an RC circuit approaches as the frequency approaches zero.
- (A) 0° (B) 45°
 (C) 180° (D) 90°

29. The nature of binding for a crystal with alternate and evenly spaced positive and negative ions is
- (A) Covalent (B) Dipolar
(C) Metallic (D) Ionic
30. Zener breakdown in a semi-conductor diode occurs when
- (A) forward current exceeds certain value
(B) forward bias exceeds certain value
(C) reverse bias exceeds certain value
(D) potential barrier is reduced to zero
31. GaAs LED emits radiation in
- (A) ultraviolet region
(B) violet, blue, green, range of visible region
(C) visible region
(D) infrared region
32. “Half-splitting” is
- (A) a means for nuclear fuel cells to produce electricity
(B) a means of isolating a problem in a circuit
(C) a means for reducing a high ac voltage to a low dc voltage
(D) a means of limiting current in a circuit
33. What device is similar to an RTD but has a negative temperature coefficient?
- (A) Strain gauge (B) Thermistor
(C) Negative-type RTD (D) Thermocouple
34. A transformer is plugged into a 120 V rms source and has a primary current of 300 mA rms. The secondary is providing 18 V across a 10 Ω load. What is the efficiency of the transformer?
- (A) 88% (B) 90%
(C) 92% (D) 95%
35. What is the standard TTL noise margin?
- (A) 5.0 V (B) 0.2 V
(C) 0.8 V (D) 0.4 V

36. Which digital IC package type makes the most efficient use of printed circuit board space?
- (A) SMT (B) TO can
(C) flat pack (D) DIP
37. A “U” shaped, opposite-polarity material built near a JFET-channel center is called the
- (A) Gate (B) Block
(C) Drain (D) Heat sink
38. A logic probe is placed on the output of a gate and the display indicator is dim. A logic pulser is used on each of the input terminals, but the output indication does not change. What is wrong?
- (A) The dim indication on the logic probe indicates that the supply voltage is probably low.
(B) The output of the gate appears to be open.
(C) The LOW indication is the result of a bad ground connection on the logic probe.
(D) The gate is a tri-state device.

39.

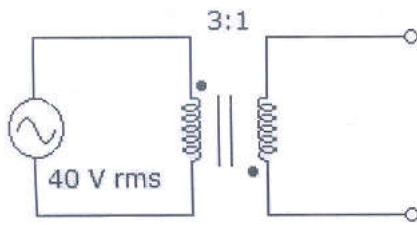

What is the secondary voltage in the given circuit?

- (A) 13.3 V rms in phase with the primary.
(B) 120 V rms in phase with the primary.
(C) 13.3 V rms out of phase with the primary.
(D) 120 V rms out of phase with the primary.
40. A special transformer used to convert unbalanced signals to balanced signals is the
- (A) Balun (B) Autotransformer
(C) Center-tapped transformer (D) Step-across transformer

41. Which of the following memories uses a MOSFET and a capacitor as its memory cell?
- (A) ROM (B) SRAM
(C) DRAM (D) DROM
42. A nonvolatile type of memory that can be programmed and erased in sectors, rather than one byte at a time is
- (A) MPROM (B) EEPROM
(C) EPROM (D) Flash memory
43. A chopper operating at a fixed frequency is feeding an RL load. As the duty ratio of the chopper is increased from 25% to 75%, the ripple in the load current
- (A) remains constant
(B) decreases, reaches a minimum at 50% duty ratio and then increases
(C) increases, reaches a maximum at 50% duty ratio and then decreases
(D) keeps on increasing as the duty ratio is increased
44. A SCR is rated at 75A peak, 20A average. The greatest possible delay in the trigger angle if the dc is at rated value is
- (A) 47.5° (B) 30° to 45°
(C) 74.5° (D) 137°
45. The applied sine voltage to a SCR is $V_M = 200$ V and $R = 10$ Ohm. If the gate trigger lags the ac supply by 120° , the average load current is
- (A) $15/n$ A (B) $5/n$ A
(C) $-5/n$ A (D) $-15/n$ A
46. A 100 VDC is applied to the inductive load through a SCR. The SCR's specified latching current is 100 mA. The minimum required width of gating pulse to turn on the SCR is
- (A) $100 \mu\text{S}$ (B) 100 S
(C) 1 mS (D) $50 \mu\text{S}$

47. A cycloconverter is a
- (A) Frequency changer from higher to lower frequency with one-stage conversion
 - (B) Frequency changer from higher to lower frequency with two-stage conversion
 - (C) Frequency changer from lower to higher frequency with one-stage conversion
 - (D) Either (A) or (C)
48. The cycloconverter require natural or forced commutation as under
- (A) Natural commutation in both step-up and step down cycloconverter
 - (B) Forced commutation in both step-up and step-down cycloconverter
 - (C) Forced commutation in step-up cycloconverter
 - (D) Forced commutation in step-down cycloconverter
49. In synchronized UJT triggering of an SCR, voltage VC across capacitor reaches UJT threshold thrice in each half cycle so that there are three firing pulses during each half cycle. The firing angle of the SCR can be controlled
- (A) Once in each half cycle
 - (B) Thrice in each half cycle
 - (C) Twice in each half cycle
 - (D) None of the above
50. A thyristor is triggered by a pulse train of 5 kHz. The duty ratio is 0.4. If the allowable average power is 100 W, the maximum allowable gate drive power is
- (A) $100\sqrt{2}$ W
 - (B) 50 W
 - (C) 150 W
 - (D) 250 W
51. A high-pass T-connected symmetrical filter section has capacitances of 400 nF in each of its series arms and an inductance of 200 mH in its shunt arm. The cut-off frequency of the filter is
- (A) 1592 Hz
 - (B) 1125 Hz
 - (C) 281 Hz
 - (D) 398 Hz
52. In a ballistic galvanometer, the deflecting torque is proportional to
- (A) The current through coil
 - (B) Square of current through coil
 - (C) Square-root of current through coil
 - (D) Sine of measured value

53. What is the significance of the J and K terminals on the J-K flip-flop?
- (A) There is no known significance in their designations
 - (B) The J represents “jump”, which is how the Q output reacts whenever the clock goes HIGH and the J input is also HIGH
 - (C) The letters represent the initials of Johnson and King, the co-inventors of the J-K flip-flop
 - (D) All of the other letters of the alphabet are already in use
54. Which of the following type of class allows only one object of it to be created?
- (A) Virtual class
 - (B) Abstract class
 - (C) Singleton class
 - (D) Friend class
55. A Hall effect sensor
- (A) exists only in theory
 - (B) is a non contacting magnetic sensor
 - (C) can operate only a few times before failure
 - (D) produces very large voltages
56. Which electromagnetic device contains an *armature*?
- (A) A speaker
 - (B) A dc generator
 - (C) A relay
 - (D) A solenoid
57. In a balanced RYB-sequences, Y-connected (Star connected) source with $V_{RN} = 100$ volts is connected to a Δ -connected (Delta connected) balanced load of $(8+j6)$ ohms per phase. Then the phase current and line current values respectively, are
- (A) 10A;30A
 - (B) $10\sqrt{3}$ A;30A
 - (C) 10A;10A
 - (D) $10\sqrt{3}$ A; $10\sqrt{3}$ A
58. If a 1 MHz carrier is amplitude modulated with a 5 kHz audio signal, the upper-side frequency is
- (A) 1005 kHz
 - (B) 1000 kHz
 - (C) 995 kHz
 - (D) None of the above

59. In an ac circuit the fundamental component of current wave lags the corresponding voltage wave by 20° . The third harmonic component of current wave lags the corresponding voltage by an angle

- (A) Less than 20° (B) More than 20°
 (C) Equal to 20° (D) Equal to or more than 20°

60. Rotation of a geosynchronous satellite means its

- (A) Drift from stationary position
 (B) Wobbling
 (C) Three-axis stabilization
 (D) Three-dimensional stabilization

61. In a superheterodyne receiver

- (A) the IF stage has better selectivity than RF stage.
 (B) the RF stage has better selectivity than IF stage.
 (C) the RF stage has same selectivity than IF stage.
 (D) None of the above

62. The sensitivity curve of a standard receiver is represented by

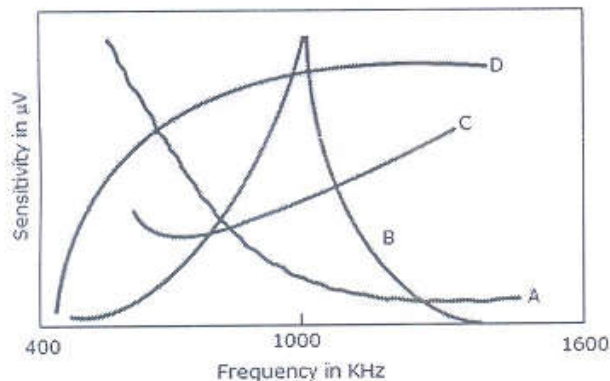

- (A) Curve A (B) Curve B
 (C) Curve C (D) Curve D

63. For the system in the given figure the characteristic equation is

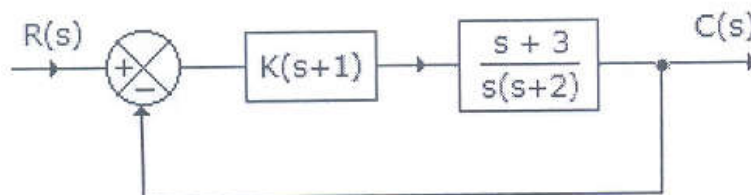

$$(A) \quad 1 + \frac{K(s+1)(s+3)}{s(s+2)} = 0$$

$$(B) \quad 1 + \frac{K(s-1)(s-3)}{s(s-2)} = 0$$

$$(C) \quad K(s+1)(s+3) = 0$$

$$(D) \quad s(s+2) = 0$$

64. A stepper motor is

- (A) a two phase induction motor
- (B) a kind of rotating amplifier
- (C) an electromagnetic transducer used to convert an angular position of shaft into electrical signal
- (D) an electromechanical chemical device which actuates a train of step angular movements in response to a train of input pulses on one to one basis.

65. First column elements of Routh's tabulation are 3, 5, $-3/4$, $1/2$, 2. It means that there

- (A) is one root in left half s plane
- (B) are two roots in left half s plane
- (C) are two roots in right half s plane
- (D) is one root in right half s plane

66. The rms value of wave in figure is

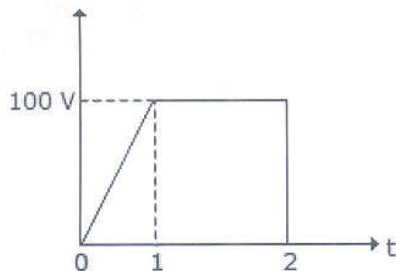

- (A) about 95 V
- (B) about 80 V
- (C) about 50 V
- (D) about 25 V

67. When a current source is suddenly connected across a two terminal relaxed RC circuit at time $t = 0$, the voltage across the current source is shown in figure. The RC circuit is

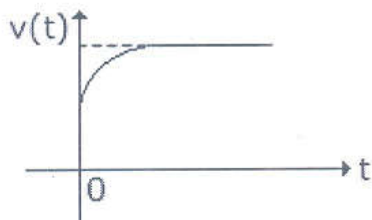

- (A) a series combination of R and C
(B) a parallel combination of R and C
(C) a series combination of R and parallel combination of R and C
(D) a pure capacitor
68. To increase Q factor of a coil, the wire should be
- (A) long (B) thin
(C) thick (D) long and thin
69. The coil of a moving iron instrument has a resistance of $500\ \Omega$ and an inductance of 1 H. It reads 250 V when a 250 V dc is applied. If series resistance is $2000\ \Omega$, its reading when fed by 250 V, 50 Hz ac will be
- (A) 260 V (B) 252 V
(C) 250 V (D) 248 V
70. The potential gradient in a cable is maximum in
- (A) conductor (B) outer sheath
(C) insulation (D) uniformly all over
71. The Q-factor of a series resonant circuit is also known as
- (A) current magnification factor (B) voltage magnification factor
(C) load factor (D) leakage factor
72. In which of these is reverse recovery time nearly zero?
- (A) Zener diode (B) Tunnel diode
(C) Schottky diode (D) PIN diode
73. A broadside array consisting of 200 cm wavelength with 10 half-wave dipole spacing 10 cm. And if each array element feeding with 1 amp current and operating at same frequency, then find the half power beamwidth.
- (A) 4° (B) 2°
(C) 10° (D) 15°
74. A wave is propagated in a waveguide at frequency of 9 GHz and separation is 2 cm between walls. Calculate group velocity for dominant mode.
- (A) 1.8×10^8 m/sec (B) 5×10^8 m/sec
(C) 3×10^8 m/sec (D) 1.5×10^8 m/sec
75. In a 3 phase fully controlled converter the firing frequency is

- (A) 3 times the line frequency (B) 6 times the line frequency
(C) 9 times the line frequency (D) 12 times the line frequency
76. The resolution of an n bit DAC with a maximum input of 5 V is 5 mV. The value of n is
- (A) 8 (B) 9
(C) 10 (D) 11
77. A device which converts BCD to seven segment is called
- (A) Encoder (B) Decoder
(C) Multiplexer (D) None of the above
78. A cordless telephone using separate frequencies for transmission in base and portable units is known as
- (A) Duplex arrangement (B) Half duplex arrangement
(C) Either (A) or (B) (D) Neither (A) nor (B)
79. A modem is classified as low speed if data rate handled is
- (A) upto 100 bps (B) upto 250 bps
(C) upto 400 bps (D) upto 600 bps
80. Neutralization is used in RF amplifiers to
- (A) stop oscillation (B) increase bandwidth
(C) improve selectivity (D) All of the above
81. Wave $A = 100 \sin \omega t$ and wave $B = 100 \cos \omega t$, then
- (A) rms values of the two waves are equal
(B) rms values of A is more than that of B
(C) rms values of A is less than that of B
(D) rms values of the two waves may or may not be equal
82. The drift velocity of electrons is
- (A) very small as compared to speed of light.
(B) equal to speed of light.
(C) almost equal to speed of light.
(D) half the speed of light.
83. A capacitor stores 0.15 C at 5 V. Its capacitance is

- (A) $0.75 F$ (B) $0.75 \mu F$
(C) $0.03 F$ (D) $0.03 \mu F$
84. A 400 W carrier is amplitude modulated with $m = 0.75$. The total power in AM is
- (A) 400 W (B) 512 W
(C) 588 W (D) 650 W
85. Non-coherently detection is not possible by
- (A) PSK (B) ASK
(C) FSK (D) Both (A) and (C)
86. Microwave resonators are used in
- (A) microwave oscillators
(B) microwave narrow band amplifier
(C) microwave frequency metres
(D) All of the above
87. As the frequency is increased, the charging MVAR in a cable
- (A) decreases
(B) increases
(C) remain the same
(D) decreases or remains the same
88. Which of the following lines is non-radiating?
- (A) Open two wire (B) Coaxial
(C) Both (A) and (B) (D) None of the above
89. MICR stands for
- (A) Magnetic Ink Chart Receipt
(B) Magnetic Ink Character Recognition
(C) Magnetic Ink Chart Recognition
(D) Magnetic Ink Character Receipt
90. Kirchoff s current law states that
- (A) net current flow at the junction is positive
(B) algebraic sum of the currents meeting at the junction is zero
(C) no current can leave the junction without some current entering it

- (D) total sum of currents meeting at the junction is zero
91. In Laplace transform, multiplication by e^{-at} in time domain becomes
- (A) translation by a in s domain
 - (B) translation by $(-a)$ in s domain
 - (C) multiplication by e^{-as} in s domain
 - (D) None of the above
92. A function having frequency f is to be sampled. The sampling time T should be
- (A) $T=1/2F$
 - (B) $T > 1/2F$
 - (C) $T < 1/2F$
 - (D) $T \leq 1/2F$
93. Transistor are free from which type of noise?
- (A) Resistance noise
 - (B) Partition noise
 - (C) Flicker noise
 - (D) Shot noise
94. Which of the following cannot be used to demodulate SSB?
- (A) Complete phase-shift generator
 - (B) Product detector
 - (C) Diode balanced modulator
 - (D) Bipolar transistor balanced modulator
95. In an RC series circuit $R = 100 \Omega$ and $X_C = 10\Omega$. In this circuit
- (A) the current and voltage are in phase
 - (B) the current leads the voltage by about 6°
 - (C) the current leads the voltage by about 84°
 - (D) the current lags the voltage by about 6°
96. Which element exhibits the property of inertia?
- (A) Resistance
 - (B) Capacitance
 - (C) Inductance
 - (D) Both resistance and inductance
97. In a coaxial cable, braided copper is used for
- (A) conductor
 - (B) shield
 - (C) dielectric
 - (D) jacket

98. At room temperature, the current in intrinsic semiconductor is due to
- (A) holes (B) electrons
(C) ions (D) holes and electrons
99. Which of the following oscillators is suitable for frequencies in the range of mega hertz?
- (A) RC phase shift (B) Wien bridge
(C) Hartley (D) Both (A) and (C)
100. If the input to the ideal comparator shown in the figure is a sinusoidal signal of 8 V (peak to peak) without any DC component, then output of the comparator has a duty cycle of

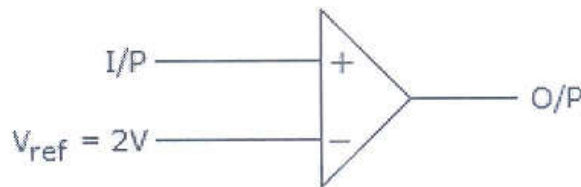

- (A) 1/2 (B) 1/3
(C) 1/6 (D) 1/12
101. The input impedance of op-amp circuit of figure is

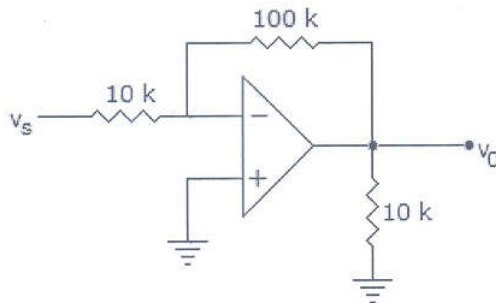

- (A) 120 k ohm (B) 100 k ohm
(C) infinity (D) 10 k ohm
102. To protect the diodes in a rectifier and capacitor input filter circuit, it is necessary to use
- (A) surge resistor (B) surge inductor
(C) surge capacitor (D) Both (A) and (B)

103. For a system to work as oscillator, the total phase shift to the loop gain must be equal to

- (A) 90° (B) 45°
(C) 270° (D) 360°

104. Bellows converts

- (A) pressure difference into displacement
(B) pressure difference into voltage
(C) displacement into pressure difference
(D) Either (A) or (C)

105. The compensator of the given figure is a

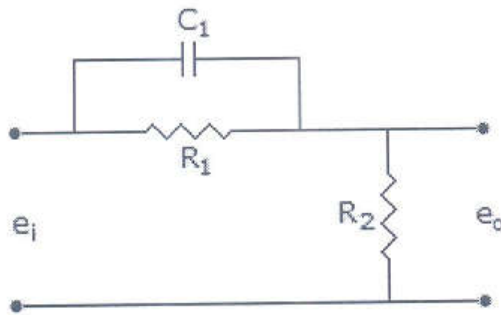

- (A) lag compensator (B) lead compensator
(C) lag-lead compensator (D) None of the above

106. A lag compensator is essentially a

- (A) low pass filter (B) high pass filter
(C) band pass filter (D) Either (A) or (B)

107. In an integral controller

- (A) the output is proportional to input
(B) the rate of change of output is proportional to input
(C) the output is proportional to rate of change of input
(D) None of the above

108. Bode magnitude plot is drawn between

- (A) magnitude of network function and ω
(B) dB magnitude and $\log \omega$
(C) dB magnitude and ω
(D) \log_e (magnitude) and $\log \omega$

109. In a minimum phase system
- (A) all poles lie in the left half plane
 - (B) all zeros lie in the left half plane
 - (C) all poles lie in the right half plane
 - (D) all except one pole or zero lie in the left half plane
110. The closed-loop voltage gain of an inverting amplifier equals
- (A) the ratio of the input resistance to the feedback resistance
 - (B) the open-loop voltage gain
 - (C) the feedback resistance divided by the input resistance
 - (D) the input resistance
111. If an op-amp has one input grounded and the other input has a signal feed to it, then it is operating as
- (A) Common-mode
 - (B) Single-ended
 - (C) Double-ended
 - (D) Non inverting mode
112. In a center tap full wave rectifier, if V_m is the peak voltage between center tap and one end of the secondary, the maximum voltage coming across the reverse bias diode is
- (A) V_m
 - (B) $2 V_m$
 - (C) $V_m/2$
 - (D) $V_m/\sqrt{2}$
113. An LED has a rating of 2 V and 10 mA. It is used along with 6V battery. The range of series resistance is
- (A) 0 to 200 Ω
 - (B) 200 – 400 Ω
 - (C) 200 Ω and above
 - (D) 400 Ω and above
114. The number of doped regions in PIN diode is
- (A) 1
 - (B) 2
 - (C) 3
 - (D) 1 or 2
115. As compared to an ordinary semiconductor diode, a Schottky diode
- (A) has lower cut in voltage
 - (B) has higher cut in voltage
 - (C) lower reverse saturation current
 - (D) Both (B) and (C)

116. A plane electromagnetic wave travels in dielectric medium of relative permittivity 9. Relative to free space, the velocity of propagation in the dielectric is
- (A) increased by a factor of 9 (B) increased by a factor of 3
(C) unchanged (D) reduced by a factor of 1/3
117. Each transistor in the Darlington pair has $h_{fe} = 100$. The overall h_{FE} of the composite transistor neglecting the leakage currents is
- (A) 10000 (B) 10001
(C) 10100 (D) 10200
118. A uniform plane wave is one in which
- (A) $\vec{E} \times \vec{H} = 0$ (B) $\vec{E} \cdot \vec{H}$
(C) \vec{E} and \vec{H} are perpendicular (D) \vec{E} and \vec{H} lie in plane
119. Which of the following should dominant wave have?
- (A) Lowest cut off frequency (B) Highest cut off frequency
(C) No attenuation (D) No phase shift
120. The value of capacitor C for dynamic equalising circuit of series connected thyristors is determined by
- (A) forward characteristics of thyristors
(B) reverse recovery characteristics of thyristors
(C) both forward and reverse recovery characteristics of thyristors
(D) None of the above
121. In a single phase full wave regulator, the firing angles in the positive and negative half cycles are generally
- (A) equal (B) different
(C) equal or different (D) different but sometimes equal
122. A two winding transformer is feeding a single phase half wave rectifier circuit. The load is purely resistive. The rms value of transformer secondary current is I_s and rms value of load current is I_{rms} . Then
- (A) $I_s = I_{rms}$ irrespective of the value of firing angle.
(B) $I_s = 0.5 I_{rms}$ irrespective of the value of firing angle.
(C) $I_s = I_{rms}$ if firing angle is less than 30° .
(D) $I_s = I_{rms}$ if firing angle is more than 30° .

123. In a ripple counter,
- (A) whenever a flip flop sets to 1, the next higher FF toggles
 - (B) whenever a flip flop sets to 0, the next higher FF remains unchanged
 - (C) whenever a flip flop sets to 1, the next higher FF faces race condition
 - (D) whenever a flip flop sets to 0, the next higher FF faces race condition
124. A 12 bit ADC is used to convert analog voltage of 0 to 10 V into digital. The resolution is
- (A) 2.44 mV
 - (B) 24.4 mV
 - (C) 1.2 V
 - (D) None of the above
125. In radar systems PRF stands for
- (A) Power Return Factor
 - (B) Pulse Return Factor
 - (C) Pulse Repetition Frequency
 - (D) Pulse Response Factor
126. Which of the following is the indirect way of FM generation?
- (A) Reactance bipolar transistor modulator
 - (B) Armstrong modulator
 - (C) Varactor diode modulator
 - (D) Reactance FM modulator
127. Which of the following devices uses a helix?
- (A) Klystron amplifier
 - (B) Klystron oscillator
 - (C) TWT
 - (D) Both (A) and (B)
128. Which of the following parameters is negligible in transmission lines?
- (A) R
 - (B) L
 - (C) C
 - (D) G
129. The size of cache memory in most microcomputers is about
- (A) a few bytes
 - (B) a few kilobytes
 - (C) a few megabytes
 - (D) a few gigabytes
130. Self-bias cannot be used in
- (A) BJT circuits
 - (B) JFET biasing
 - (C) E-MOSFET
 - (D) Depletion mode operation

131. The power requirements of a DRAM in active and stand by modes is about
- (A) 350 mW and 5 mW respectively
 - (B) 350 mW each
 - (C) 5 mW each
 - (D) 350 mW and 100 mW respectively
132. Which of the following real variable names is not valid in Fortran?
- (A) BETA
 - (B) ALPHA
 - (C) A
 - (D) AB * 2
133. Which of the following cannot be used as a variable name in C?
- (A) Else
 - (B) Coal
 - (C) Ram
 - (D) Vendy
134. EEPROM permits
- (A) read operation only.
 - (B) read and byte erase operations.
 - (C) read, byte erase and byte write operations.
 - (D) read, byte erase, byte write and chip erase operations.
135. $\delta(t)$ is
- (A) an energy signal
 - (B) a power signal
 - (C) neither energy nor power
 - (D) None of the above
136. The Fourier series of an odd periodic function contains
- (A) odd harmonics only
 - (B) even harmonics only
 - (C) cosine harmonics only
 - (D) sine harmonics only
137. A transmitter serial current contains
- (A) carrier frequencies
 - (B) audio frequencies
 - (C) radio frequencies
 - (D) None of the above
138. In a radio receiver, if the intermediate frequency is too high
- (A) selectivity will be poor
 - (B) tracking difficulties will be least
 - (C) adjacent channel rejection will improve
 - (D) All of the above will occur

139. An amplifier has a large ac input signal. The clipping occurs on both the peaks. The output voltage will be nearly a

- (A) sine wave (B) square wave
(C) triangular wave (D) (A) or (C)

140. In figure $I_D = 4 \text{ mA}$. Then $V_S =$

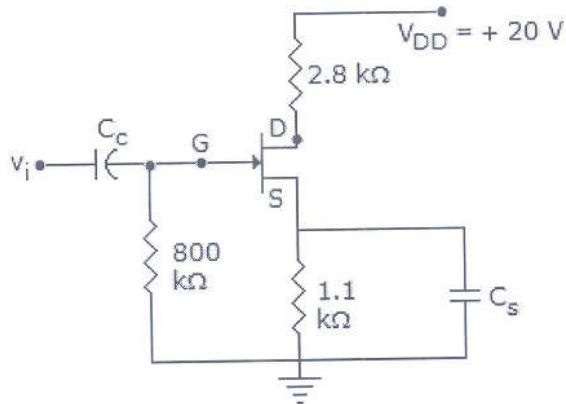

- (A) 20 V (B) 4.4 V
(C) 0.4 V (D) 0.44 V

141. The self bias provides

- (A) stable Q point (B) large voltage gain
(C) high input impedance (D) high base current

142. When a capacitor is used in place of a resistor in an op-amp network, its placement determines

- (A) open-or closed-loop gain (B) integration or differentiation
(C) saturation or cutoff (D) addition or subtraction

143. A forward voltage of 9 V is applied to a diode in series with a $1 \text{ k}\Omega$ load resistor. The voltage across load resistor is zero. It indicates that

- (A) diode is short circuited
(B) diode is open circuited
(C) resistor is open circuited
(D) diode is either short circuited or open circuited

144. Which power amplifier can deliver maximum load power?

- (A) Class A (B) Class AB
(C) Class B (D) Class C

145. The selectivity of most receivers is determined largely by
- (A) sensitivity
 - (B) characteristics of IF section
 - (C) antenna direction
 - (D) All of the above
146. FM amplifier in a superheterodyne receiver
- (A) increases selectivity
 - (B) suppresses noise
 - (C) provides improved tracking
 - (D) improves the rejection of the image frequency
147. Double integration of a unit step function would lead to
- (A) an impulse
 - (B) a parabola
 - (C) a ramp
 - (D) a doublet
148. Which of the following is not a valid integer constant in C (for 16 bit)?
- (A) 321
 - (B) -162
 - (C) -65321
 - (D) +1
149. How many logic states does an S-R flip-flop have?
- (A) 2
 - (B) 3
 - (C) 4
 - (D) 7
150. An ideal amplifier should have
- (A) high input current
 - (B) zero offset
 - (C) high output impedance
 - (D) moderate gain
